

# MAGNAPLUS® GENERATOR

## 280–430 Frame Installation, Operation, and Maintenance Manual



Marathon Electric Mfg. Corp.

A REGAL-BELOIT COMPANY

P.O. Box 8003

Wausau, WI 54402-8003

Phone: (715) 675 3359

Fax: (715) 675 8026

[www.marathonelectric.com](http://www.marathonelectric.com)

## CONTENTS

Safety	2
Receiving and Storage	2
Principles of Operation	3 - 4
Installation	4 - 6
Wiring Connections	6 - 9
Operation	9 - 10
Maintenance	11 - 12
Testing	12 - 13
Service	13 - 15
Troubleshooting	15 - 18
Specifications	19
Parts List & Recommended Spare Parts	20 - 22

## SAFETY

**PLEASE REMEMBER SAFETY FIRST.** If you are not sure of the instructions or procedures contained herein, seek qualified help before continuing.

This service manual emphasizes the safety precautions necessary during the installation, operation, and maintenance of your MagnaPLUS® generator. Each section of this manual has caution and warning messages. These messages are for your safety, and the safety of the equipment involved. If any of these cautions or warnings are not readily understood, seek clarification from qualified personnel before proceeding.

Before any service work is done, disconnect all power sources and lock out all controls to prevent an unexpected start up of the generator set driver. Proper grounding (earthing) of the generator frame and distribution system in compliance with local and national electrical codes and specific site requirements must be provided. These safety precautions are necessary to prevent potential serious personal injury, or even death.

The hazards associated with lifting or moving your MagnaPLUS® generator are pointed out in the installation and maintenance sections. Incorrect lifting or moving can result in personal injury or damage to the unit.

Prior to start up of the unit ensure that all generator leads are properly connected to the generator link board located inside the connection box. Always assume that there will be voltage present at the generator terminals whenever the generator's shaft is rotating, and proceed accordingly. Residual voltage is present at the generator terminals and at the automatic voltage regulator panel connections even with the regulator fuse removed. Caution must be exercised, or serious injury or death can result.

This manual is not intended to be a substitute for properly trained personnel. Installation and repairs should only be attempted by qualified, trained people. The cautions and warnings point out known conditions and situations that are potentially hazardous. Each installation may well create its own set of hazards.

When in doubt, ask. Questions are much easier to handle than mistakes caused by a misunderstanding of the information presented in this manual.

## RECEIVING AND STORAGE

### RECEIVING AND STORAGE

Upon receipt of the generator, it is recommended that it be carefully examined for possible shipping damage. The generator was given to the freight carrier in good condition; thus, the carrier is responsible for the product from the factory dock to the destination. Any damage should be noted on the freight bill before accepting the shipment. Any claims for damage must be promptly filed with the delivering carrier.

### UNPACKING AND HANDLING

Carefully read all instruction tags shipped with the unit. When lifting, attach an overhead crane to the lifting lug(s) on the generator frame. Apply lifting forces in a vertical direction. When transporting single bearing generators, the generator's rotor must be adequately supported to prevent damage.

#### WARNING

**THE LIFTING LUG(S) ON THE GENERATOR ARE DESIGNED TO SUPPORT THE GENERATOR ONLY. DO NOT LIFT A COMPLETE GENERATOR AND DRIVER ASSEMBLY BY MEANS OF LIFTING LUG(S) ON THE GENERATOR. PERSONAL INJURY OR EQUIPMENT DAMAGE MAY RESULT.**

### STORAGE

In the event that the generator is not immediately installed on its prime mover, it is recommended that the unit be stored indoors in a clean, dry area which is not subject to rapid changes in temperature and humidity. If the generator is stored for a long period of time, the generator should be tested, cleaned and dried as required before being put into service. See the maintenance section of this manual for further information. If the unit has been stored in an area where it has been subject to vibration, it is recommended that the bearing(s) be inspected and replaced as necessary.

# PRINCIPLES OF OPERATION

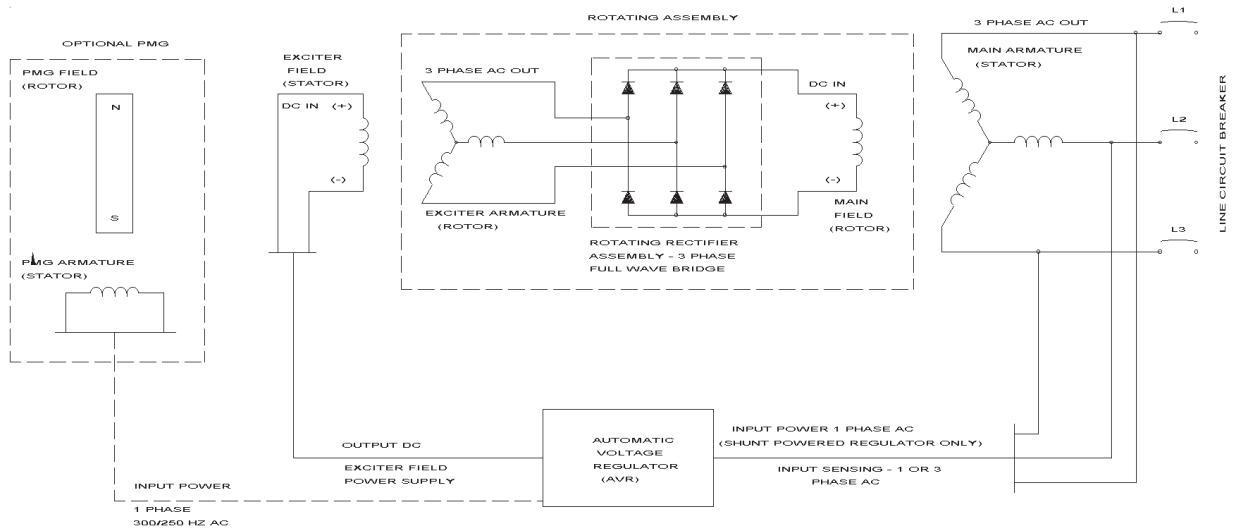

**FIGURE 1 -- MagnaPLUS® Circuit Diagram**

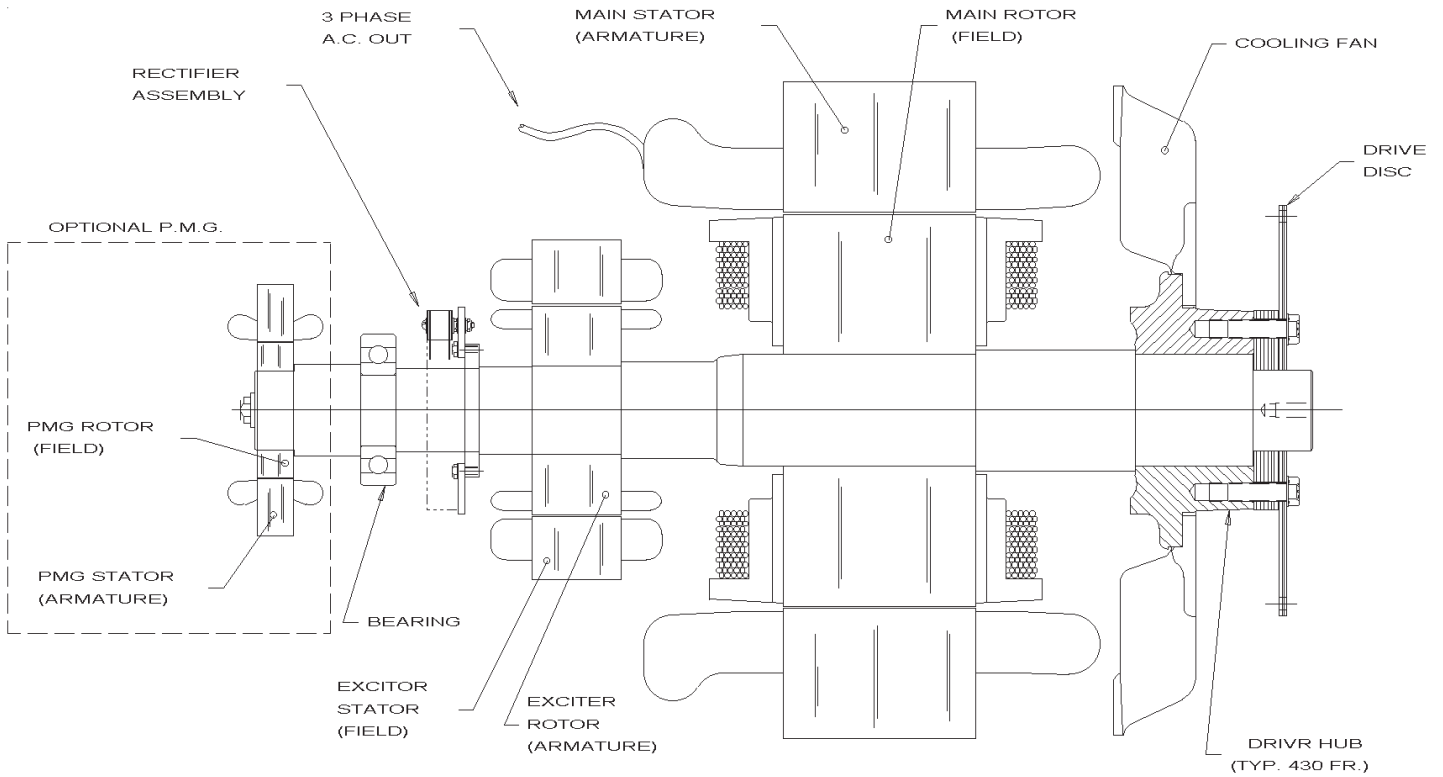

**FIGURE 2 -- Typical MagnaPLUS® Layout Diagram**

# PRINCIPLE OF OPERATION

MagnaPLUS® generators are brushless, self excited, externally voltage regulated, synchronous AC generator. The generator is made up of six major components: main stator (armature), main rotor (field), exciter stator (field), exciter rotor (armature), rectifier assembly, and voltage regulator. In understanding the above terminology, note the following: stators are stationary, rotors rotate, a field is a DC electrical input, and an armature is an AC electrical output. These system components are electrically interconnected as shown in Figure 1 and physically located as shown in Figure 2.

The generator's exciter consists of a stationary field and a rotating armature. The stationary field (exciter stator) is designed to be the primary source of the generator's residual magnetism. This residual magnetism allows the exciter rotor (armature) to produce AC voltage even when the exciter stator (field) is not powered. This AC voltage is rectified to DC by the rotating rectifier assembly and fed directly to the main rotor (field). As the generator shaft continues to rotate, the main rotor (field) induces a voltage into the generator's main stator (armature). At rated speed, the main stator's voltage produced by the residual magnetism of the exciter allows the automatic voltage regulator to function. The regulator provides voltage to the exciter field resulting in a build-up of generator terminal voltage. This system of using residual magnetism eliminates the need for a special field flashing circuit in the regulator. After the generator has established the initial residual voltage, the regulator provides a controlled DC field voltage to the exciter stator resulting in a controlled generator terminal voltage.

## Voltage Regulation

In the standard configuration (shunt excited), the automatic voltage regulator receives both its input power and voltage sensing from the generator's output terminals (See Figure 1). With the optional PMG configuration, the regulator receives input power from the PMG. The regulator automatically monitors the generator's output voltage against an internal reference set point and provides the necessary DC output voltage to the exciter field required to maintain constant generator terminal voltage. The generator's terminal voltage is changed by adjusting the regulator's reference set point. Consult the regulator manual for specific adjustment and operating instructions.

## MOTOR STARTING

When a motor is started, a large surge of current is drawn by the motor. This starting current is equivalent to the motors locked rotor or stall current and is 5 to 10 times normal full load current. When the generator supplies this in-rush of starting current, the generator voltage dips temporarily. If the motor is too large for the generator, the generator's voltage dips greater than 30 percent. This may result in the motor starter de-energizing or the motor stalling. MagnaPlus® generators generally supply .3 to .4 horsepower per

generator KW in motor starting capability. For specific data contact Marathon Electric.

## PARALLEL OPERATION

All MagnaPlus® generators are built with 2/3 pitch main stator windings and full amortisseur (damper) windings. These features make the MagnaPlus® generators suitable for parallel operation when equipped with the proper voltage regulators and voltage regulator accessories. Consult with the factory for further information relative to parallel operations.

## NONLINEAR LOADING

Solid state electronic control devices (variable frequency drives, precision motor controls, battery chargers, etc.) utilize electronic switching circuits (thyristors, SCRs, Diodes, etc.). These switching circuits introduce high frequency harmonics which distort the normal wave form of the generator. This creates additional heat in the generator windings and may cause the generator to over-heat. Problems which can occur are not limited to the generator. Poor wave shape may adversely effect various loads connected to the generator. Consult Marathon Electric for further information relative to nonlinear loads.

---

# INSTALLATION

## PREPARATION FOR USE

Although the generator has been carefully inspected and tested in operation prior to shipment from the factory, it is recommended that the generator be thoroughly inspected. Check all bolts for tightness and examine the insulation on lead wires for chafing prior to proceeding with installation. Remove all shipping tapes, bags, skids and rotor support blocking. For two bearing units, rotate the shaft by hand to ensure that it rotates smoothly without binding.

**⚠️ WARNING**

**DISABLE AND LOCKOUT ANY ENGINE CRANKING DEVICES BEFORE ATTEMPTING TO INSTALL OR SERVICE THE GENERATOR. FOR ELECTRIC START SETS, DISCONNECT THE CRANKING BATTERY. FOR AIR START, DISCONNECT THE AIR SUPPLY. FOR MOTOR GENERATOR SETS, OPEN THE POWER SUPPLY TO THE DRIVE MOTOR. FAILURE TO COMPLY WITH THESE SAFETY PROCEDURES COULD RESULT IN SEVERE PERSONAL INJURY OR EQUIPMENT DAMAGE.**

**NEVER "BAR OVER" THE ENGINE GENERATOR SET USING THE GENERATOR'S FAN. THE FAN IS NOT DESIGNED FOR THIS PURPOSE. BARRING OVER THE SET WITH THE FAN COULD DAMAGE THE FAN AND RESULT IN PERSONAL INJURY OR EQUIPMENT DAMAGE.**

## GENERATOR MOUNTING

### Single Bearing Units.

Single bearing units are provided with an SAE flywheel housing adapter flange and flexible drive discs. Coupling the generator's shaft to the engine flywheel is accomplished with special steel drive discs bolted to the shaft. In addition to the drive discs, there may be a hub spacer, spacer discs, or a combination of hub spacer and spacer discs inserted between the drive discs and the shaft to achieve the proper shaft extension ("G" dimension per SAE J620c). Holes are provided in the periphery of the coupling discs which correspond to tapped holes in the prime mover's flywheel. The outside diameter of the drive discs fit in a rabbet in the flywheel so that concentricity is assured.

Grade 8 place bolts and hardened washers are recommended to mount the drive discs to the flywheel. **DO NOT USE SPLIT TYPE LOCK WASHERS.** Split lock washers when biting into the drive disc cause stress risers which may result in the disc fracturing.

The SAE flywheel housing adapter ring and the engine flywheel housing are designed to match each other with no further alignment necessary. Use grade 5 or greater mounting bolts. MagnaPLUS® generator frames are constructed with two or three bolt holes per foot. The feet should be shimmed where necessary to obtain solid contact with the sub-base. With the frame securely bolted to the engine flywheel housing, there is no side thrust or pull on the generator frame, thus no real need to secure the feet with more than one bolt per foot.

## GENERATOR MOUNTING

### Two Bearing Generators -- Direct Drive

Two bearing generators are provided with a keyed shaft extension. For direct drive generators, the assembler furnishes a flexible coupling which is installed between the driver and the generator's shaft. Aligning the generator and its driver as accurately as possible will reduce vibration, increase bearing life, and ensure minimum coupling wear. It may be necessary to shim the generator feet for proper support and alignment. Secure the feet of the generator with grade 5 or greater bolts through the holes provided in the mounting feet. Consult the coupling manufacturer's instructions for alignment specifications and procedures.

## GENERATOR MOUNTING

### Two Bearing Units -- Belt Driven

Two bearing MagnaPLUS® generators can be belt driven provided belts are sized and applied correctly. Please refer to your supplier of belts and sheaves for correct sizing and tensioning specifications. A bearing life calculation should be performed. Marathon Electric recommends a minimum B-10 life of 40,000 hours. If cog type belts are used, a vibration may be introduced which could lead to premature failure of the bearings.

## HYDRAULIC DRIVE WITH SHAFT SPLINE

### Two Bearing Units

All 280 PDL MagnaPLUS® two bearing hydraulic drive generators are equipped with a Zerk grease fitting mounted in the drive end of the shaft. Prior to assembly to the hydraulic drive motor, lightly coat the hydraulic drive motor shaft, and/or grease the generator spline per the greasing instructions in the MAINTENANCE section, page 12. **DO NOT assemble the generator to the hydraulic drive motor with the spline dry.**

## END PLAY TESTING

Refer to the engine manual for recommended end play specifications and measurement procedures. If end play is not to specification, it is an indication that the generator shaft is not moving freely in the assembly, and normal life of the thrust bearing could be impaired. Probable causes of this problem are:

1. Improper seating of drive discs in the flywheel resulting in misalignment.
2. Improper mating of generator frame to engine flywheel housing resulting in misalignment.
3. Improper "G" dimension per SAE J620c on either the engine or generator.

## TORSIONAL VIBRATION

Torsional vibrations are generated in all rotating shaft systems. In some cases, the amplitude of these vibrations at critical speeds may cause damage to either the generator, its driver, or both. It is therefore necessary to examine the torsional vibration effect on the entire rotating system. IT IS THE RESPONSIBILITY OF THE GENERATOR SET ASSEMBLER TO ASSURE THE TORSIONAL COMPATIBILITY OF THE GENERATOR AND ITS DRIVER. Drawings showing pertinent dimensions and weights of the rotating assembly will be supplied by Marathon Electric upon request.

## ENVIRONMENTAL CONSIDERATIONS

The MagnaPLUS® generator is designed for heavy duty industrial applications; however, dirt, moisture, heat and vibration are enemies of rotating electrical machinery. Excessive exposure to the elements may shorten generator life. The temperature of the cooling air entering the intake openings of the generator should not exceed the ambient temperature shown on the generator's nameplate. Generators intended for outdoor application should be protected with housings having adequate ventilation. Although the standard insulation systems are moisture and humidity resistant, space heaters are recommended for extreme conditions. If the generator is to be installed in an area where blowing sand and dust are present, the enclosure should be fitted with filters. Filters reduce erosion on the generator's insulation by blocking high velocity abrasive particles generated by the flow of cooling air through the generator. Consult the factory for appropriate filters and generator deratings required.

The generator conduit box construction allows cable entry from multiple sides. A hole saw or other appropriate tool may be used to provide for conduit entrance. Protect the interior of the generator from shavings when drilling or sawing. An approved connector must be used in conjunction with the conduit. To minimize the transmission of vibration, it is essential that flexible conduit be used for all electrical entrance to the generator conduit box.

All MagnaPLUS® generators are equipped with link boards (terminal strips) for both internal and external connections. All connections made to the studs of the link board should be made with high quality ring terminals. Ring terminal sizes are: 6 mm (280 Series Frames) and 10 mm (360 and 430 Series Frames). Torque link board connections to the following specifications: 280 frame -- 5.4 NM (4 Ft Lb); 360 & 430 frame -- 27 NM (20 Ft Lb).

Refer to the connection diagram supplied with the generator and / or the proper diagrams shown in this manual. Install all inter component and external wiring in accordance with national and local electrical codes. The neutral in the following connection diagrams shown below may be either grounded (earthed) or left above ground potential (floating). See national and local codes and / or the system distribution wiring schematic diagram for the proper connection of the neutral.

**The following connection diagrams are shown for twelve lead generators. Ten lead generators have the same terminal designations except for leads T10, T11, and T12. These three leads are internally connected inside the generator and brought out as a single lead (T0). Ten lead generators can only be connected in a wye configuration.**

## WIRING CONNECTIONS

Wiring of the generator and accessories should be done in accordance with good electrical practices. Follow government, industry and association standards.

### HIGH (SERIES) WYE CONNECTION

VOLTAGE (HIGH WYE)		
Hz	L-L	L-Lo
60	380	219
	416	240
	440	254
	460	266
	480	277
50	380	219
	400	231
	415	240
	440	254

### LOW (PARALLEL) WYE CONNECTION

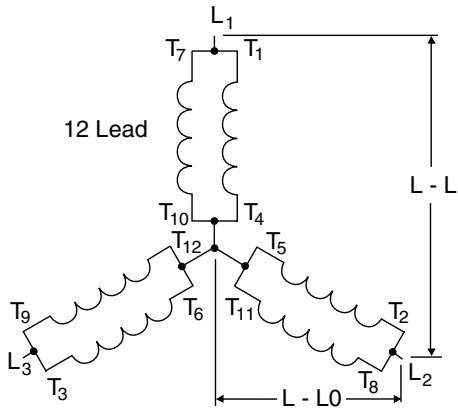

VOLTAGE (LOW WYE)		
Hz	L-L	L-L0
60	190	110
	208	120
	220	127
	230	133
	240	139
50	190	110
	200	115
	208	120
	220	127

### HIGH (SERIES) DELTA CONNECTION

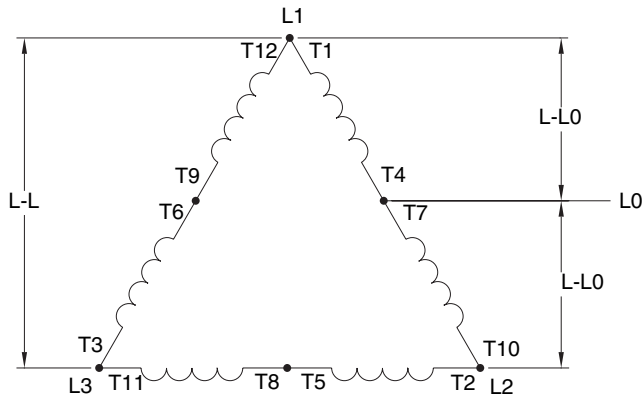

VOLTAGE (HIGH DELTA)		
Hz	L-L	L-L0
60	240	120
	277	139
	240	120
50	200	100
	220	110
	240	120

### LOW (PARALLEL) DELTA CONNECTION

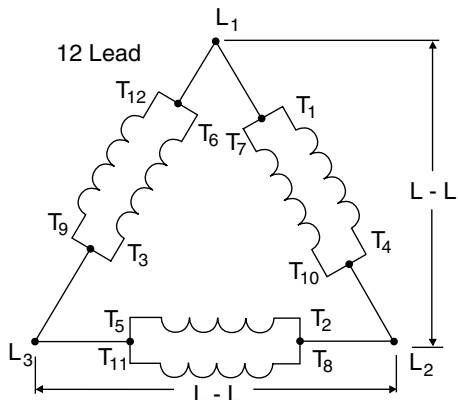

VOLTAGE (LOW DELTA)	
Hz	L-L
60	110
	120
50	100
	110

## DOUBLE DELTA -- SINGLE PHASE CONNECTION

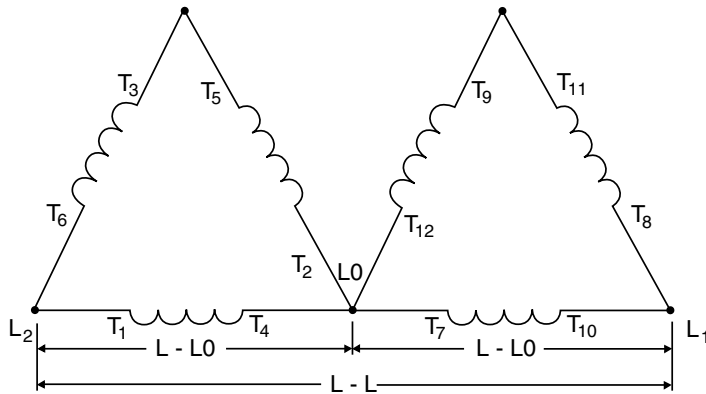

VOLTAGE (DOUBLE DELTA)		
Hz	L-L	L-LO
60	200	100
	220	110
	240	120
50	220	110

Note: Single phase KW/KVA ratings are approximately equal to 50% of the generator's three phase ratings.

## LOW ZIG ZAG -- SINGLE PHASE (PARALLEL) CONNECTION

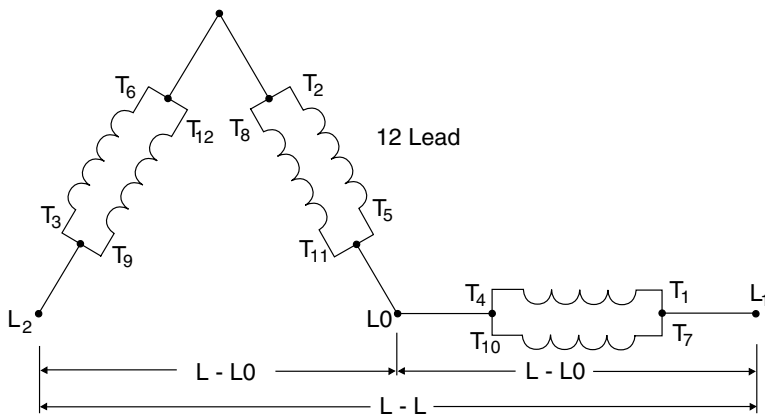

VOLTAGE (LOW ZIGZAG)		
Hz	L-L	L-LO
60	200	100
	220	110
	240	120
50	220	110

Note: Single phase KW/KVA ratings are approximately equal to 50% of the generator's three phase ratings.

## HIGH ZIG ZAG -- SINGLE PHASE (SERIES) CONNECTION

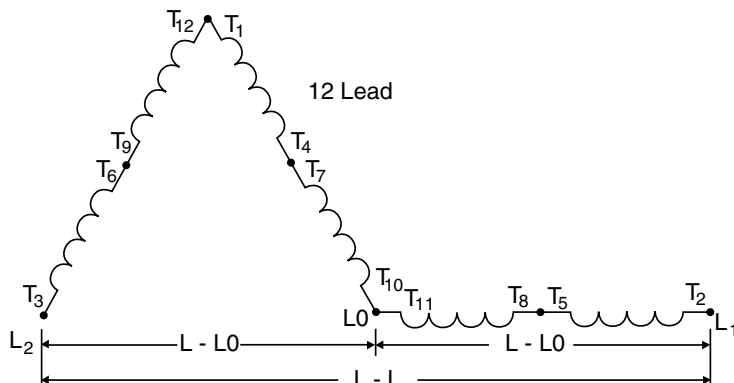

VOLTAGE (LOW ZIGZAG)		
Hz	L-L	L-LO
60	480	240

Note: Single phase KW/KVA ratings are approximately equal to 50% of the generator's three phase ratings.

### DEDICATED SINGLE PHASE CONNECTION HIGH VOLTAGE - SERIES CONNECTED

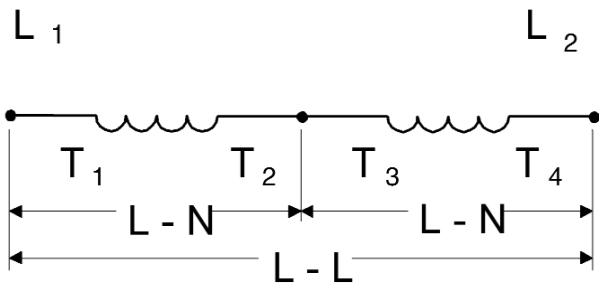

VOLTAGE (DEDICATED)		
Hz	L-L	L-N
60	240	120
	220	110
50	220	110
	200	100

### SINGLE PHASE CONNECTION - SINGLE VOLTAGE PARALLEL

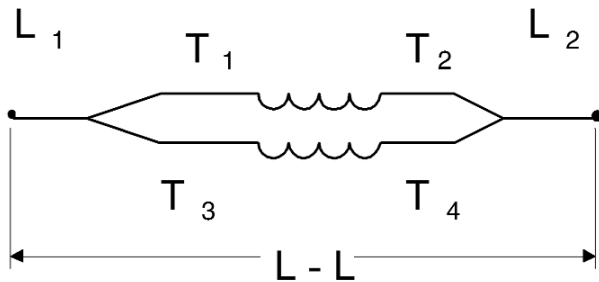

VOLTAGE	
	L-L
60 HZ	120
50 HZ	110

Note: For 120 volt only service. Use an AVC63-4A or a VR63-4C voltage regulator to replace the standard SE350 regulator.

# OPERATION

## PRE-START INSPECTION

Before starting the generator for the first time, the following inspection checks are recommended:

1. A visual inspection should be made for any loose parts, bad connections, or foreign materials.
2. Bar the set over by hand for at least 2 revolutions to be sure that there is no interference and that the set turns freely. If the set does not turn freely, check for clearance in the generator and exciter air gap.
3. Check all wiring against the proper connection diagrams, and ensure that all connections and terminations are tight and properly insulated.
4. Verify that all equipment is properly grounded (earthed).

 **WARNING**

**MAGNAPLUS® GENERATORS MAY HAVE VOLTAGE PRESENT AT THE LEAD TERMINALS WHEN THE SHAFT IS ROTATING. DO NOT PERMIT OPERATION OF THE GENERATOR UNTIL ALL LEADS HAVE BEEN CONNECTED AND INSULATED. FAILURE TO DO THIS MAY RESULT IN PERSONAL INJURY OR EQUIPMENT DAMAGE.**

5. Clear the surrounding area of any materials that could be drawn into the generator.
6. Check all fasteners for tightness.
7. Check all access plates, covers, screens and guards. If they have been removed for assembly or inspection, reinstall and check for security.
8. Review all prime mover prestart up instructions, and ensure that all recommended steps and procedures have been followed.
9. Remove any masking materials affixed during painting. Inspect the generator, prime mover, and any accessory equipment to ensure that nameplates, and all safety warning / caution signs and decals provided with the equipment are in place and clearly visible.

**Note: It is strongly recommended that the authority having jurisdiction over the installation site be consulted to determine if any additional warning or caution notices, or additional safety devices are required by local codes / standards. Any such required notices or devices should be installed prior to initial startup.**

## START-UP

The following procedure should be followed when starting the generator set for the first time.

1. The generator output must be disconnected from the load. Be sure that the main circuit breaker or fused disconnect is in the open position.
2. Open the input power to the automatic voltage regulator. Remove the fuse or disconnect and insulate one of the regulator input power leads. (See separate regulator manual)
3. Verify that all prime mover start-up procedures have been followed.
4. If the unit is provided with space heaters, ensure that they are de energized. In some installations, a set of auxiliary contacts on the main circuit breaker or transfer switch will automatically open the space heater circuit when the generator is connected to the load.
5. Start the prime mover, and adjust it for proper speed. See generator nameplate.
6. The purpose of this initial test with the regulator out of the circuit is to detect any wiring mistakes without exposing the unit to undue risk. Check all line to line and line to neutral voltages for balanced voltage. If voltages are balanced, shut down the set and reconnect the regulator. If voltages are unbalanced, shut down the equipment and check for improper wiring. If the problem persists, consult the factory.

With the regulator de energized, the residual voltage should be 10 - 25% of rated value. It is recommended that this residual voltage and driver RPM be recorded for use as a future troubleshooting benchmark.

 **WARNING**

**THE FOLLOWING TEST MUST BE CONDUCTED BY QUALIFIED ELECTRICAL PERSONNEL. LETHAL VOLTAGE MAY BE PRESENT AT BOTH THE GENERATOR AND VOLTAGE REGULATOR TERMINALS DURING THIS PROCEDURE. CAUTION MUST BE EXERCISED NOT TO COME INTO PERSONAL CONTACT WITH LIVE TERMINALS, LINKS, OR STUDS. SERIOUS INJURY OR DEATH COULD RESULT.**

7. Start the set and adjust the terminal voltage to the desired value by means of the regulator voltage adjustment. If the regulator is equipped with a stability adjustment, follow the instructions in the regulator manual to adjust the stability. Again, check all line to line and line to neutral voltages for balance. It is

recommended practice to record the no load excitation (DC voltage to the exciter stator), generator terminal voltage, and driver speed as a benchmark for future troubleshooting.

8. Close the main circuit breaker to the load.
9. Monitor the generator output current to verify that it is at or below nameplate value.
10. Check generator speed (frequency) under load. Adjust as necessary. (Refer to prime mover or governor manuals)

## SHUTDOWN PROCEDURE

There are no specific instructions for shutting down the generator; however, several good practices should be observed to prolong equipment life.

1. It is advisable to disconnect all loads (open main circuit breaker or disconnect) prior to shutdown. This is especially important if loads can be damaged by low voltage or low frequency conditions during generator "coast down".
2. Isolate all conditions that could apply voltage to the generator terminals while the generator is at rest. Failure to comply could result in personnel injury or equipment damage.
3. If the unit is equipped with space heaters, verify that the heater circuit is energized.

---

## MAINTENANCE

The following maintenance procedures should be followed to ensure long equipment life and satisfactory performance. Maintenance intervals will depend upon operating conditions.

1. Routinely check intake and exhaust air screens to ensure that they are clean and free of debris. Clogged intake air screens will reduce cooling air flow and result in higher operating temperatures. This will reduce generator life and may result in generator damage.
2. All MagnaPLUS® generators are equipped with double shielded ball bearings lubricated for the life of the bearing. Every 1,000 hours check the bearing(s) for smooth, quiet operation. For continuous duty generators, recommended practice is to replace the bearing during major overhauls of the engine.
3. Periodically inspect the unit for any buildup of contamination (dirt, oil, etc.) on the windings. If the wound components have become coated with heavy concentrations of oil and grime, the unit should be disassembled and thoroughly cleaned. This operation is not one that can be accomplished effectively on site, but

rather one that should be conducted by an authorized service center equipped with the appropriate apparatus and solvents necessary to properly clean and dry the generator.



**THE FOLLOWING TEST MUST BE CONDUCTED BY QUALIFIED ELECTRICAL PERSONNEL. LETHAL VOLTAGE MAY BE PRESENT AT BOTH THE GENERATOR AND VOLTAGE REGULATOR TERMINALS DURING THIS PROCEDURE. CAUTION MUST BE EXERCISED NOT TO COME INTO PERSONAL CONTACT WITH LIVE TERMINALS, LINKS, OR STUDS. SERIOUS INJURY OR DEATH COULD RESULT.**

4. Every 2,000 operating hours or in conjunction with scheduled engine maintenance, check the DC no load excitation voltage per item #7 in the startup procedure. Compare this voltage with the value recorded during initial startup. If this value of no load excitation voltage is markedly higher than the bench mark reading, it is an indication of problems in either the exciter, main field, or the rotating rectifier assembly. Ensure that RPM is the same as initial test.
5. Monitor and record insulation resistance with a 500 volt mega-ohm meter. The minimum acceptable reading is 2 mega-ohms. If the reading drops below the minimum, the generator should be cleaned and dried at an authorized service shop. Consult Marathon Electric for more information.

## DRYING WINDINGS

Generators in service may inadvertently have their windings exposed to splashing or sprayed water. Units that have been in transit or storage for long periods of time may be subjected to extreme temperature and moisture changes causing excessive condensation. Regardless of the source of moisture, wet windings should be thoroughly dried out before operating the unit. If this precaution is not taken, serious damage to the generator can result. The following procedures may be utilized in drying the generator's windings. The method selected will be influenced by winding wetness and situation limitations.

### Space Heaters

An electric heater may have been supplied with the generator. When energized from a power source other than the generator, the heater will gradually dry the generator. This process can be accelerated by enclosing the unit with a covering and inserting additional heating units. A hole should be left at the top of the covering to permit the escape of moisture. Care should be taken not to overheat various accessory equipment mounted with the generator.

## Forced Air

Another method to dry the generator is to run the set with no excitation (see startup procedure item #2). The natural flow of ambient air through the generator will tend to dry the windings. This method can be accelerated by adding a source of heat at the air intake to the generator. Heat at point of entry should not exceed 80 C (180° F).

## HYDRAULIC DRIVE GENERATORS, SHAFT SPLINE LUBRICATION

The shaft spline should be greased prior to initial assembly to the driver, and every three (3) months to reduce maintenance, and prolong the life of the spline coupling per the following procedure:

1. Material: Molybdenum Disulfide - sometimes referred to as "Molly Grease."
2. Turn the rotor assembly so that the Zerk fitting is in line with the access hole in the top of the drive end bearing bracket as illustrated in Figure 3.
3. Using a hand held grease gun with a solid coupling, apply a small amount of grease into the fitting. **DO NOT OVER GREASE.** Limit the amount of grease to one (1) trigger pull of the grease gun.

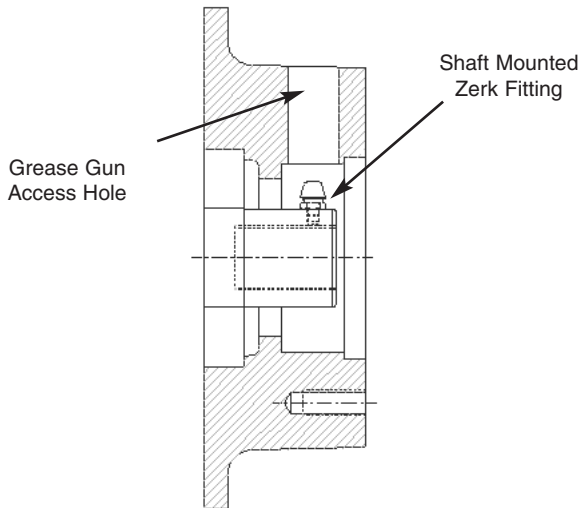

Figure 3--Drive End Bearing Bracket

---

## TESTING

### Visual Inspection

Remove covers and look for any obvious problems: burnt windings, loose connections, broken wires, frayed insulation, cracked brackets, missing hardware, etc. Check for foreign objects which may have been drawn into the generator. Verify

that the generator's air gaps (main rotor and exciter) are free from obstructions. If possible, rotate the generator manually to ensure free rotation. Never "bar over" the engine generator set using the generator fan.

### **WARNING**

**THE FOLLOWING TEST MUST BE CONDUCTED BY QUALIFIED ELECTRICAL PERSONNEL. LETHAL VOLTAGE MAY BE PRESENT AT BOTH THE GENERATOR AND VOLTAGE REGULATOR TERMINALS DURING THIS PROCEDURE. CAUTION MUST BE EXERCISED NOT TO COME INTO PERSONAL CONTACT WITH LIVE TERMINALS, LINKS, OR STUDS. SERIOUS INJURY OR DEATH COULD RESULT.**

### CONSTANT EXCITATION TEST (12V BATTERY TEST)

The generator "no load" voltage is dependent on exciter input voltage and generator speed. With the generator operating at rated speed and 12 volts dc applied to the exciter field, the generator's terminal voltage will be near rated value.

1. Shutdown the generator set and connect a voltmeter on the generator terminals.
2. Disconnect the regulator's F+ (F1) and F- (F2) leads and connect them to a 12V battery. Caution should be taken to ensure that the battery is not exposed to any potential arcing.
3. With no load on the generator (main breaker open) run the generator at rated speed. Measure the generator's terminal voltage and compare this value with values recorded during installation.

If voltage readings are normal, the main generator and excitation are operating properly. Troubleshooting should continue with the regulator. If readings are not normal the problem is in the generator. Continue testing diodes, surge suppressor, and windings.

### Continuity / Resistance Test

The generator has four components which can be checked using an ohm meter: exciter stator, exciter rotor, main stator and main rotor. Each of these components are comprised of various windings which form a complete electrical path of relatively low resistance. Using an ohm meter measure the loop resistance of each component. Compare these measured values with the values listed in the specification section of this manual. Note that very small resistance values require precision equipment to make accurate measurements; however, a standard ohm meter will provide a good indication of winding continuity.

## Insulation Test

Insulation resistance is a measure of the integrity of the insulating materials that separate the electrical windings from the generator's steel core. This resistance can degrade over time or be degraded by contaminants: dust, dirt, oil, grease, and especially moisture. Most winding failures are due to a breakdown in the insulation system. In many cases, low insulation resistance is caused by moisture collected when the generator is shutdown

Insulation resistance is measured with a megger (mega-ohm meter). A megger measures insulation resistance by placing 500 volts between the winding and the frame of the generator. Caution must be taken to remove all electronic devices (regulators, diodes, surge protectors, capacitors, protective relays, etc.) from the winding circuit before checking the insulation. Winding insulation can be checked on the main stator, main rotor, exciter stator, and exciter rotor. Minimum resistance is 2 mega-ohms. If the winding resistance is low it must be dried (see maintenance section) or repaired.

## DIODE TESTING

If the generator is close coupled to an engine, it may be necessary to "bar over" the engine in order to gain access to a given area of the rectifier assembly. NEVER use the generator's fan as a fulcrum to accomplish this. Use the engine manufacturer's recommended practice to manually turn over the engine. To prevent possible injury to personnel, and damage to the equipment, ensure that the engine cannot start during this procedure.

Remove the two main rotor leads and the three exciter rotor leads from the rectifier assembly (Figure 5). The rectifier assembly is now electrically isolated from the generator. The diodes remain mounted and the diode leads remain connected to the terminal posts. Using an ohmmeter or a battery light continuity tester, place one test probe on the diode lead terminal post. In succession, touch the other test probe to the lead screw hole in each heat sink. Reverse the probes and repeat the procedure. You have now tested the three diodes connected to this terminal post in both the forward and reverse direction. Repeat the procedure using the other diode terminal post.

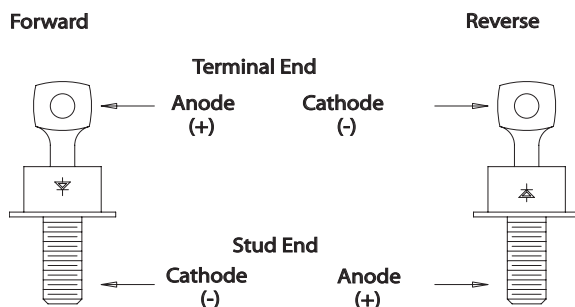

FIGURE 4: DIODE POLARITY

When the positive test probe is connected to the diode's anode and the negative test probe is connected to the diode's cathode (forward biased), the diode will switch on and conduct electricity (Figure 4). This is observed by a low resistance reading when using an ohm meter or the lighting of the bulb when using a battery light continuity tester. Reversing the test leads (reverse biased) will result in the diode switching off and no electricity will be conducted. The results of these tests should indicate one of three conditions:

1. **Good diode:** Will have a much greater resistance in one direction than the other. Typical reverse biased resistance will be 30,000 ohms or greater, while forward biased resistance will be less than 10 ohms. The battery light tester will have the light "on" in one direction and "off" in the other.
2. **Shorted condition:** Ohmmeter reading will be zero, or very low in both directions. The continuity tester will have the light "on" in both directions.
3. **Open condition:** Ohmmeter will have a maximum (infinity) reading in both directions. Continuity tester light will be off in both directions.

Diode failure after a 25 hour "run in" period is generally traceable to external causes such as a lightning strike, reverse current, line voltage spikes, etc. All 6 diodes are essentially in the same circuit. When a diode is stressed to failure, there is no easy method to determine remaining life in the other diodes. To avoid possible continued failures, it is recommended that the entire rectifier assembly be replaced rather than replacing individual diodes.

---

## SERVICE

### GENERAL

The service procedures given in this section are those which can reasonably be conducted on-site with a minimum number of special tools and equipment. All service procedures should be conducted by qualified maintenance personnel. Replacement parts may be ordered through an authorized service center or directly from the factory.

### FIELD FLASHING

#### Restoring Residual Magnetism (not applicable on PMG equipped generators)

To restore residual magnetism to the generator, connect a 12 volt battery to the exciter field while the generator using the following procedure:

1. Shutdown the generator set. Remove the exciter field leads F+ and F- from the regulator.



**Failure to remove the exciter field leads from the automatic voltage regulator during flashing procedures may destroy the regulator.**

2. Connect the F+ and F- leads to the battery's corresponding positive and negative terminals. This should be done using an appropriate length of lead wire to separate the battery from the point of connection (batteries may explode when exposed to an electric arc). After 3 to 5 seconds, remove the F- lead. An inductive arc should result. If no arc is drawn, repeat the procedure.
3. Reconnect the F+ and F- leads to the regulator. Restart the generator and verify that terminal voltage is developed. If terminal voltage does not develop, repeat the field flashing procedure and / or consult the trouble shooting section.

## BEARING REMOVAL

Prior to performing this operation, it is suggested that the alternator's shaft be rotated until two of the main rotor poles are in a vertical position. Once the bearing bracket is backed out, the rotor will drop on the main stator core. Having the rotor in this position will limit the amount of rotor drop to that of the air gap. Visually inspect the bearing bore for damage or wear. If worn or damaged, replace prior to reassemble.

### Opposite Drive End Bearing Bracket Removal.

Prior to proceeding with bracket removal, disconnect exciter field leads F+ and F- from the automatic voltage regulator and ensure that they are free to move when the bearing bracket is removed. Remove the bearing bracket retaining bolts. Using a pair of screw drivers, wedge the bracket off the frame. After approximately 1/8 inch, the bracket will clear the locating register on the frame and will drop until the rotor is resting on the main stator core. Continue to pull the bracket free from the bearing. Visually inspect the bearing bore and o-ring (if equipped) for damage or wear. If worn or damaged, repair or replace prior to reassembly.

### Drive End Bearing Bracket Removal, Two Bearing Units.

Remove any drive arrangement from the generator shaft extension. Remove the bearing lock ring retaining screws. There is no o-ring in the drive end bearing bracket. The shaft extension must be supported before proceeding further. A hoist and sling, jack, or some other means of support with a capacity of 2 tons should be used.

Remove the bearing bracket retaining cap screws. Using a flat bladed screw driver or chisel, pry the bracket back from the frame. After approximately 1/8 inch, the bracket will clear the locating register on the frame. Lower the shaft extension until the rotor is resting on the main stator core. Continue to pull the bracket free from the bearing. Visually inspect the bearing bore for damage or wear. If worn or damaged, sleeve or replace prior to reassembly.

Reassembly note: Before the bearing bracket is seated against the frame, a threaded rod may be used to help align the inner bearing cap with the bearing bracket.

## BEARING REPLACEMENT

Using a bearing puller, remove the existing bearing. It is strongly recommended that the bearing be replaced any time the it is removed from the shaft. **ALWAYS** install the same type and size bearing that was supplied as original equipment. Order by part number from the parts list, and include the unit serial number and part number when ordering. Heat the bearing to a maximum of 100°C (212°F) in an oven. Apply a thin coat of clean lubricating oil to the press fit area of the rotor shaft. Using suitable heat resistant gloves, install the bearing over the end of the shaft until it seats against the shaft shoulder. The bearing should slide on the shaft and be seated without excessive force. Should the bearing bind on the shaft prior to being seated against the shoulder, a piece of tubing slightly larger than the press fit area can be used to drive the bearing to its final position. Using light taps with a soft mallet, apply pressure to the inner race only.

## RECTIFIER ASSEMBLY REMOVAL

The rectifier assembly cannot be removed until the opposite drive end bearing bracket and bearing have been removed (see bearing removal procedure). Remove the three exciter rotor leads from the heat sinks and the two main rotor leads from the main rotor posts (see Figures 5). Remove the screws securing the rectifier assembly and pull the assembly free from the shaft.

## DIODE REPLACEMENT

Prior to installing a replacement diode on the heat sink, apply a thin film of conductive heat sink compound around the base of the diode (do not coat the threads). When installing a diode on the heat sink, care should be taken not to over torque the retaining nut which could cause damage to the device. Torque to 28 pound inches. If not damaged, the existing diode lead wire may be unsoldered from the failed diode, and resoldered on the replacement.

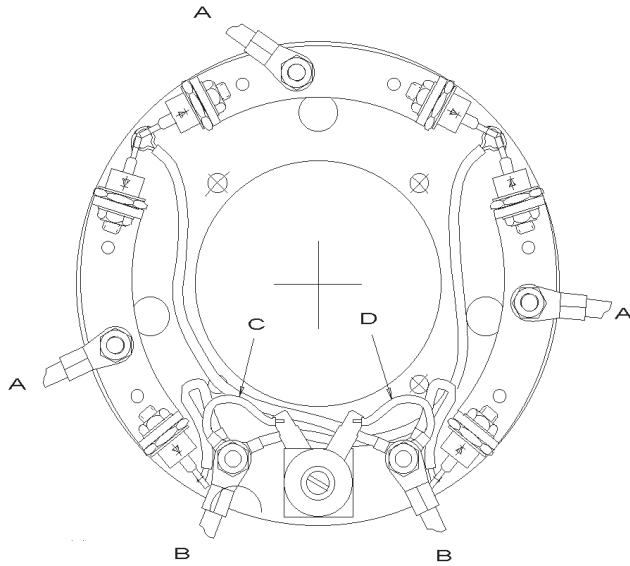

430 FRAME

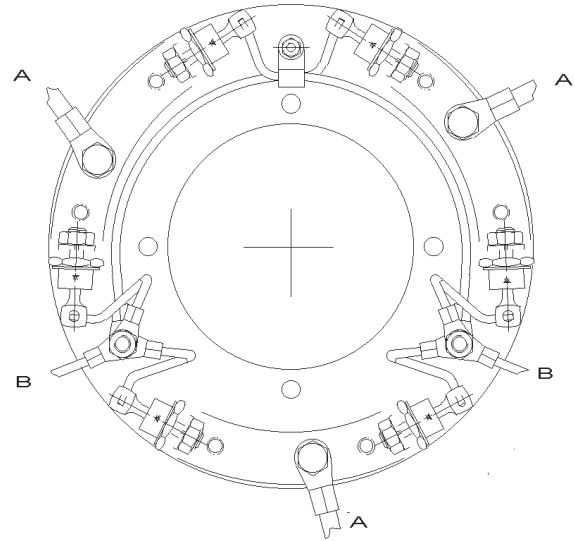

280 / 360 FRAME

A - Exciter Rotor Lead, B - Main Rotor Lead, C - Red (+) Suppressor Lead, D - Black (-) Suppressor Lead

FIGURE 5: ROTATING RECTIFIER ASSEMBLY

## RETURNED GOODS

Contact Marathon Electric Manufacturing Corporation for authorization before returning any product. We can not be responsible for any items returned without authorization.



**Single bearing generators must have their rotor assembly properly secured to prevent damage during transit to the factory, or to an authorized service center.**

## TROUBLESHOOTING

This section is intended to suggest a systematic approach to locating and correcting generator malfunctions. The section is arranged according to the symptoms of the problem. The steps have been arranged in an attempt to do the easy checks first and prevent further damage when troubleshooting a disabled machine.

The first step of troubleshooting is to gather as much information as is possible from operating personnel and individuals present during the failure. Typical information includes: how long the unit had been operating; what loads were on line; weather conditions; protective equipment that did or did not function. In addition, information as to the operating condition of the generator's prime mover is vital. Has the prime mover been maintaining constant speed? If not, have there been extended periods of under speed operation? Has the prime mover experienced an over-speed condition? If yes, what was the maximum speed, and how long did the unit operate at that elevated speed?

The generator speed should be maintained at rated nameplate value during all operating tests. The frequency of the generator depends upon rotational speed. Most regulators used with MagnaPLUS® generators have built in under frequency protection such that if the speed is reduced more than 5%, the voltage will drop off rather rapidly with further reductions in speed.



**WARNING**

HIGH VOLTAGES MAY BE PRESENT AT THE GENERATOR'S TERMINALS WHEN THE UNIT IS RUNNING. SOME ACCESSORY EQUIPMENT SUCH AS SPACE HEATERS MAY BE ENERGIZED FROM AN OUTSIDE POWER SOURCE WHEN THE UNIT IS AT REST. TOOLS, EQUIPMENT, CLOTHING AND YOUR BODY MUST BE KEPT CLEAR OF ROTATING PARTS AND ELECTRICAL CONNECTIONS. SPECIAL PRECAUTIONS MUST BE TAKEN DURING TROUBLESHOOTING SINCE PROTECTIVE COVERS AND SAFETY DEVICES MAY BE REMOVED OR DISABLED TO GAIN ACCESS AND PERFORM TESTS. BE CAREFUL. SERIOUS PERSONAL INJURY OR DEATH CAN RESULT FROM THESE HAZARDS. CONSULT QUALIFIED PERSONNEL WITH ANY QUESTIONS.

## **GENERATOR PRODUCES NO VOLTAGE**

### **CAUSE**

### **CHECK AND REMEDY**

Voltmeter off or defective	Check voltage with a separate meter at the generator terminals.
Incorrect or defective connections	Verify generator connections. See drawings supplied with the generator or lead connection diagrams in this manual. Inspect all wiring for loose connections, open circuits, grounds, and short circuits.
Loss of residual	Flash the field. Refer to field flashing in the service section. If the generator is equipped with a PMG, field flashing is not necessary -- check regulator fuse and input power from the PMG.
Defective diodes, suppressor, or windings	Test the generator using the 12 volt battery test as specified in the testing section. If the results indicate generator problems, perform insulation, continuity, and diode tests as specified in the testing section.
Regulator protection operating	Adjust regulator. Consult regulator manual.
Regulator inoperative	Adjust or replace regulator. Consult regulator manual.

## **GENERATOR PRODUCES LOW VOLTAGE, NO LOAD**

### **CAUSE**

### **CHECK AND REMEDY**

Underspeed operation	Check speed using a tachometer or frequency meter.
Voltmeter off or defective	Check voltage with a separate meter at the generator terminals.
Incorrect or defective connections	Verify generator connections. See drawings supplied with the generator or lead connection diagrams in this manual. Inspect all wiring for grounds, open circuits and short circuits.
Loss of regulator power	Check regulator fuse and input power. Input power is produced by the generator's residual voltage or from an optional PMG.
Regulator adjustment	Adjust regulator settings. Consult regulator manual.
Regulator incorrectly connected	Review the generator connection diagram or reference the regulator manual.
Defective diodes, suppressor, or windings	Test the generator using the 12 volt battery test as specified in the testing section. If the results indicate generator problems, perform insulation, continuity, and diode tests as specified in the testing section.
Regulator inoperative	Adjust or replace regulator. Consult regulator manual.

## GENERATOR PRODUCES LOW VOLTAGE WHEN LOAD APPLIED

CAUSE	CHECK AND REMEDY
Excessive load	Reduce load. The load on each leg should be evenly balanced, and rated current should not be exceeded on any leg.
Large motor starting or low load power factor	Motor starting currents are too large for the generator. When starting multiple motors, sequence the motors and start the largest motors first. Reduce lagging power factor load.
Driver speed droop or belt slip	Check driver. If belt driven, check belt tension. Check under frequency setting on regulator. Under frequency voltage roll-off may be activated.
Reactive droop	If the generator is equipped for parallel operation, some droop is normal as reactive load increases. When operating as a single unit, the parallel CT can be shorted to eliminate this effect. Refer to Regulator manual.
Line drop	If voltage is proper at generator terminals but low at load terminals, increase external wire size.
Defective diodes, suppressor, or windings	Test the generator using the 12 volt battery test as specified in the testing section. If the results indicate generator problems, perform insulation, continuity, and diode tests as specified in the testing section.

## GENERATOR PRODUCES FLUCTUATING VOLTAGE

CAUSE	CHECK AND REMEDY
Fluctuating engine speed	Check engine and governor systems for malfunctions. Check load for fluctuation.
Regulator stability	Adjust Regulator stability. Refer to Regulator manual.
Regulator external rheostat	Replace defective or worn rheostat. Use shielded cable to minimize electrical noise.
Defective rectifier assembly	Check assembly for loose connections. Test the diodes as specified in the test section.
Loose terminal or load connections	Improve connections both mechanically and electrically.
Defective regulator	Replace regulator.

## GENERATOR PRODUCES HIGH VOLTAGE

CAUSE	CHECK AND REMEDY
Faulty metering	Check voltage with separate meter at generator terminals.
Incorrect connections	Verify generator connections. Refer to drawings supplied with the generator or connection diagrams in this manual.
Regulator adjustments	Adjust regulator. Consult regulator manual.
Leading power factor	Check the power factor of the load. If power factor is leading, change load configuration. Excessive leading power factor (capacitors) can cause voltage to climb out of control.
Incorrect regulator connection	Verify regulator voltage sensing is connected correctly. Consult regulator manual.
Defective regulator	Replace regulator.

## GENERATOR BUILDS VOLTAGE FROM STARTUP, THEN GOES TO LOW (RESIDUAL) VOLTAGE

### CAUSE

### CHECK AND REMEDY

Regulator protective circuit operating      Check indicators on regulator. Correct problems and adjust regulator as is required. Refer to regulator manual.

## GENERATOR IS OVERHEATING

### CAUSE

### CHECK AND REMEDY

Generator is overloaded      Reduce load. Check with ammeter and compare with nameplate rating.

Clogged ventilating screens      Clean air passages.

High room temperature or altitude      Improve ventilation or reduce load.

Insufficient circulation of cooling air      Generator location and enclosure design must provide adequate air flow and minimize recirculation of hot air.

Unbalanced load      The load on each leg should be as evenly balanced as possible and should not exceed rated current on any one leg.

## GENERATOR PRODUCES MECHANICAL NOISE

### CAUSE

### CHECK AND REMEDY

Defective bearing      Replace bearing.

Loose or misaligned coupling      Tighten, realign, or replace coupling.

Belt slap or loose guards      Check belt tensioning. Check belt guard fasteners.

## EQUIPMENT RUNS NORMALLY ON UTILITY POWER, BUT WILL NOT RUN ON GENERATOR SET

### CAUSE

### CHECK AND REMEDY

Distorted voltage waveform      Analyze load. Excessive SCR (thyristor) loading will cause distortion. Some equipment may be sensitive to distorted waveforms. Refer to Marathon Electric..

Improper generator voltage or frequency      Check name plates of devices comprising the load. Compare required voltage and frequency with that of the generator. Adjust driver speed and/or generator voltage as necessary to match generator output to load requirements.



**Compare required voltage, frequency, and KVA with generator nameplate to ensure adequate generator capacity. If in doubt, consult Marathon Electric for information regarding generator capacity.**

# SPECIFICATIONS

MODEL / FRAME SIZE	EXCITER RESISTANCE	
	STATOR	ROTOR
281, 282, 283, 284, 285, 286, 287	18.0	.120
361, 362, 363 -- three phase	23.5	.120
361, 362, 363 -- dedicated single phase	23.0	.135
431, 432, 433 -- three phase	18.5	.120
431, 432 -- dedicated single phase	18.0	.105

MODEL	GENERATOR RESISTANCE		EXCITER FIELD NO LOAD VOLTS 480 V / 60 HZ
	STATOR*	ROTOR	
281PSL1500	4.20	.400	11.0
281PSL1501	4.15	.400	11.0
281CSL1502	0.47	0.72	6.40
281PSL1502	3.20	.439	9.0
282PSL1703	1.07	0.34	14.70
282CSL1504	1.24	0.80	6.20
282PSL1704	1.07	0.34	14.70
282CSL1505	0.87	0.90	5.80
282PSL1705	0.74	0.37	14.35
283CSL1506	0.54	1.00	8.20
283PSL1706	0.45	0.40	12.95
283CSL1507	0.44	1.18	9.20
283PSL1707	0.39	0.46	11.20
284CSL1508	0.29	1.36	10.00
284PSL1708	0.27	0.52	14.18
284CSL1542	0.27	1.36	8.30
284PSL1742	0.22	0.54	14.00
285PSL1700	0.20	0.58	11.90
286PSL1701	0.14	0.72	10.68
287PSL1702	0.12	0.79	10.9
361CSL1600	.381	.750	11.8
361CSL1601	.264	.810	12.5
361CSL1602	.181	.990	14.1
362CSL1604	.138	1.05	12.2
362CSL1606	.098	1.20	10.8
363CSL1607	.069	1.37	12.2
431CSL6202	.021	.811	15.1
431CSL6204	.048	.637	13.6
431CSL6206	.037	.679	13.82
431CSL6208	.013	.715	12.20
432PSL6210	.021	.811	15.1
432PSL6212	.023	.866	14.1
433PSL6216	.012	1.067	16.2
433PSL6220	.012	.974	15.6

DEDICATED SINGLE PHASE	GENERATOR RESISTANCE		EXCITER FIELD NO LOAD VOLTS 480 V / 60 HZ
	STATOR	ROTOR	
281PSL1500	4.20	.400	11.0
281CSL1513	0.47	0.72	6.40
281PSL1511	1.420	.381	8.3
281PSL1512	1.106	.395	8.1
281PSL1513	.632	.430	8.7
282CSL1515	0.21	0.82	6.2
282PSL1714	0.19	0.35	13.0
282PSL1715	0.19	0.35	13.0
282PSL1716	0.11	0.36	12.4
283CSL1517	0.08	1.14	12.7
283PSL1717	0.5	0.41	11.8
283PSL1718	0.07	0.46	10.1
284CSL1518	0.06	1.41	12.5
284CSL1550	0.05	1.48	16
284PSL1750	0.05	0.55	11.1
285PSL1711	0.04	0.58	11.0
286PSL1712	0.03	0.71	9.7
287PSL1713	0.02	0.78	12.3
361PSL1611	.070	.750	17.5
361PSL1612	.043	.857	16.1
361CSL1613	.037	.926	13.6
362CSL1615	.019	1.20	17.0
363CSL1617	.012	1.35	23.0
431PSL6222	.025	.516	9.9
431PSL6224	.013	.615	13.8
431PSL6226	.009	.643	15.1
432PSL6228	.007	.852	11.2

\* Stator resistance measured line to line in a high wye connection.

# PARTS LIST – SINGLE BEARING

## Typical Generator Cross Section

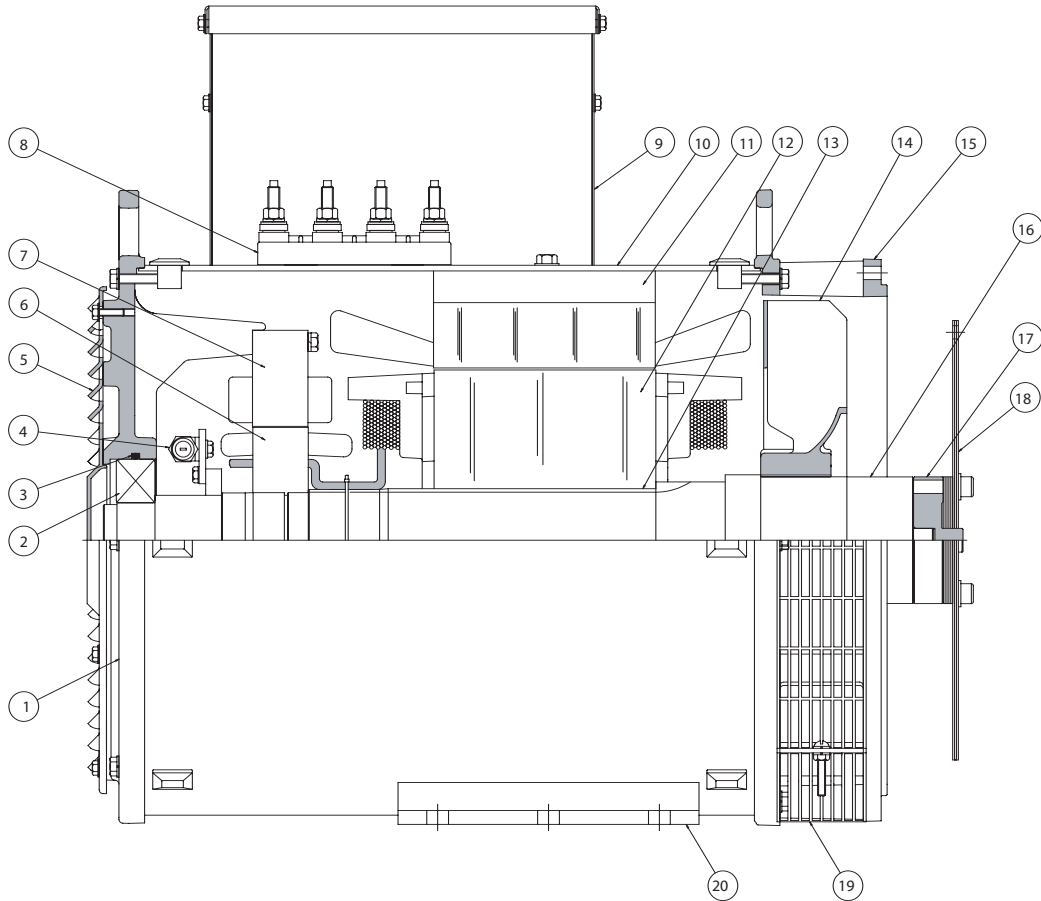

Reference Number	Part Name	Reference Number	Part Name
1	End Bracket (under end cover 360 & 430 frames)	11	Main Stator
2	Bearing	12	Main Rotor
3	O-ring (280 and 360 frame only)	13	Rotor Integral Keyway
4	Rectifier Assembly	14	Fan
5	Air Intake Cover	15	Mounting Adapter (SAE)
6	Exciter Rotor	16	Shaft
7	Exciter Stator	17	Drive Hub
8	Link Board (terminal block)	18	Drive Disk (SAE)
9	Conduit Box	19	Exhaust Screen (drip cover not shown)
10	Generator Frame	20	Mounting Base

Note: Illustration above is a 360 frame MagnaPLUS®. Other Frame sizes are typical. Optional PMG not shown. The generator model and serial numbers are required when ordering parts.

# PARTS LIST – DUAL BEARING

## Typical Generator Cross Section

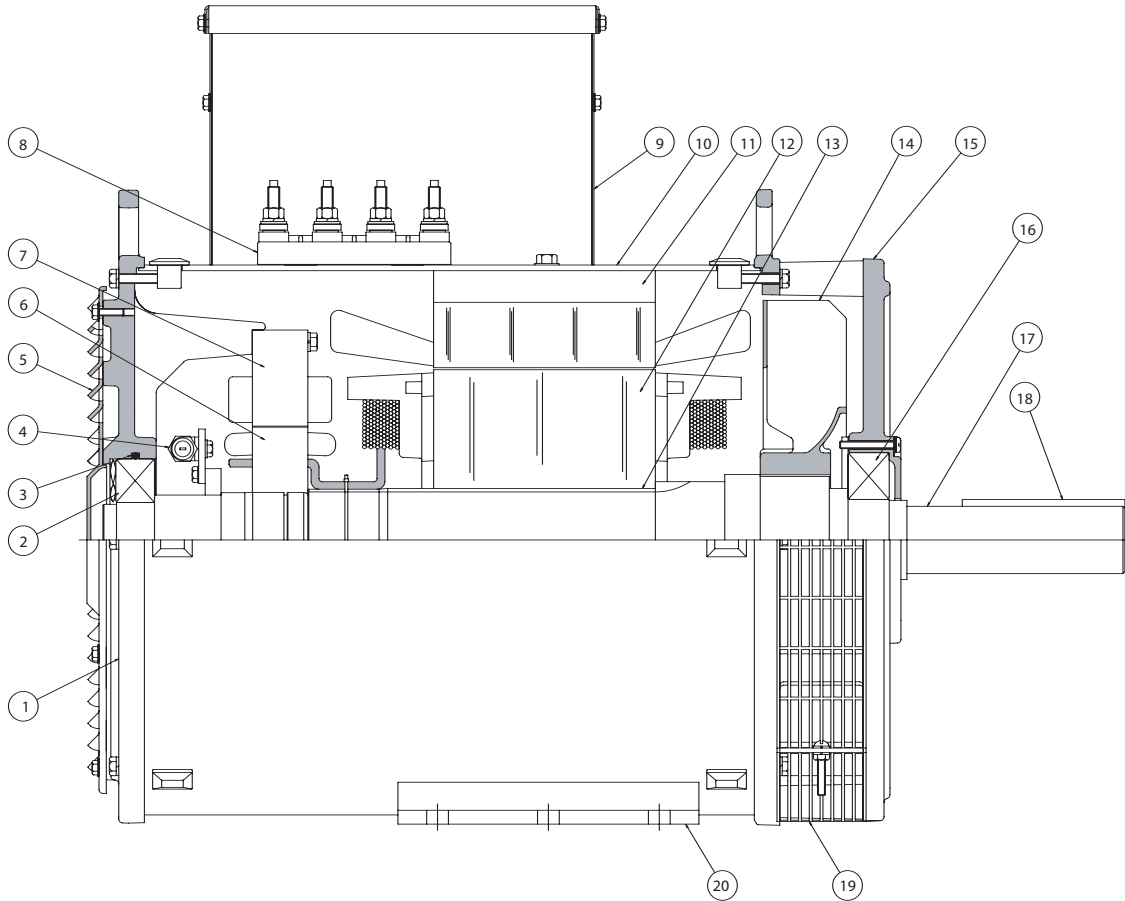

Reference Number	Part Name	Reference Number	Part Name
1	End Bracket (under end cover 360 & 430 frames)	11	Main Stator
2	Bearing (nondrive end)	12	Main Rotor
3	O-ring (280 and 360 frame only)	13	Rotor Integral Keyway
4	Rectifier Assembly	14	Fan
5	Air Intake Cover	15	End Bracket (drive end)
6	Exciter Rotor	16	Bearing (drive end)
7	Exciter Stator	17	Shaft
8	Link Board (terminal block)	18	Key
9	Conduit Box	19	Exhaust Screen (drip cover not shown)
10	Generator Frame	20	Mounting Base

Note: Illustration above is a 360 frame MagnaPLUS®. Other Frame sizes are typical. Optional PMG not shown. The generator model and serial numbers are required when ordering parts.

# PARTS LIST – PMG GENERATORS

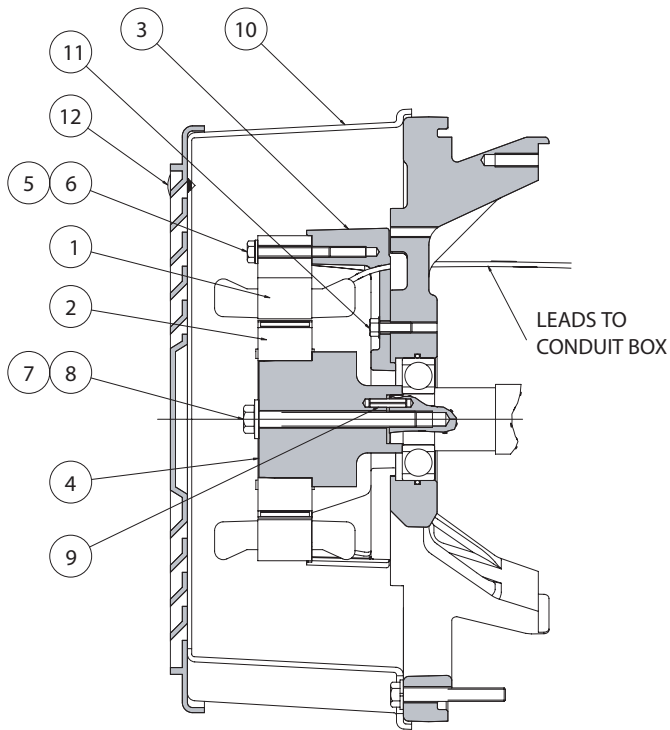

**Typical 280 and 360 Frame Add-On PMG**

Item	Description	Qty
1	PMG Stator Assembly	1
2	PMG Rotor Assembly	1
3	Stator Adaptor	1
4	Shaft, PMG rotor	1
5	Screw, Hex Hd Flg Lock 1/4 - 20	4
6	Washer, Belleville - 1/4	4
7	Hex Hd Cap Screw, 1/2 - 13 x 4"	1
8	Washer, Belleville - 1/2	4
9	Roll Pin 0.25 x .88	1
10	Drip Cover - PMG Add-on	1
11	Screw, Hex Hd Flg Lock 1/4-20	4
12	Pushpin	4

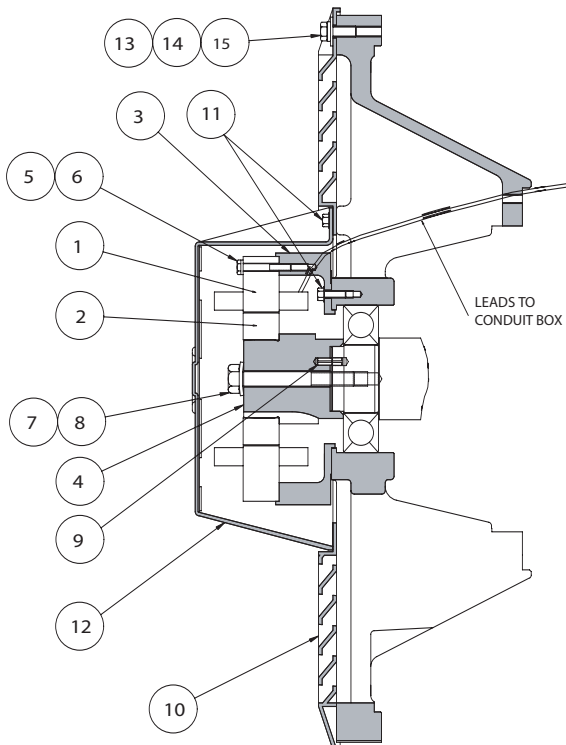

**Typical 430 Frame Add-On PMG**

Item	Description	Qty
1	PMG Stator Assembly	1
2	PMG Rotor Assembly	1
3	Stator Adaptor	1
4	Shaft, PMG rotor	1
5	Screw, Hex Hd Flg Lock 1/4 - 20	4
6	Washer, Belleville, 1/4	4
7	Hex Hd Cap Screw, 1/2 - 13 x 4"	1
8	Washer, Belleville, 1/2	1
9	Roll Pin 0.25 x .88	1
10	Air Intake - PMG Add-on	1
11	Screw, Hex Hd Flg Lock 1/4 - 20	4
12	PMG Cover	1
13	Hex Hd Cap Screw, 3/8 - 16	6
14	Washer, flat - 3/8	6
15	Washer, split lock - 3/8	6





Marathon Electric Mfg. Corp.  
P.O. Box 8003  
Wausau, WI 54402-8003 USA  
Phone: 715.675.3359  
Fax: 715.675.8026  
[www.marathonelectric.com](http://www.marathonelectric.com)  
Printed in USA  
SB504 05/06